



# DCOE Low profile linkage

Suitable for 38-55mm DCOE/SP  
Single & Twin Carburettor Sets  
LW4245 - For top mounting only

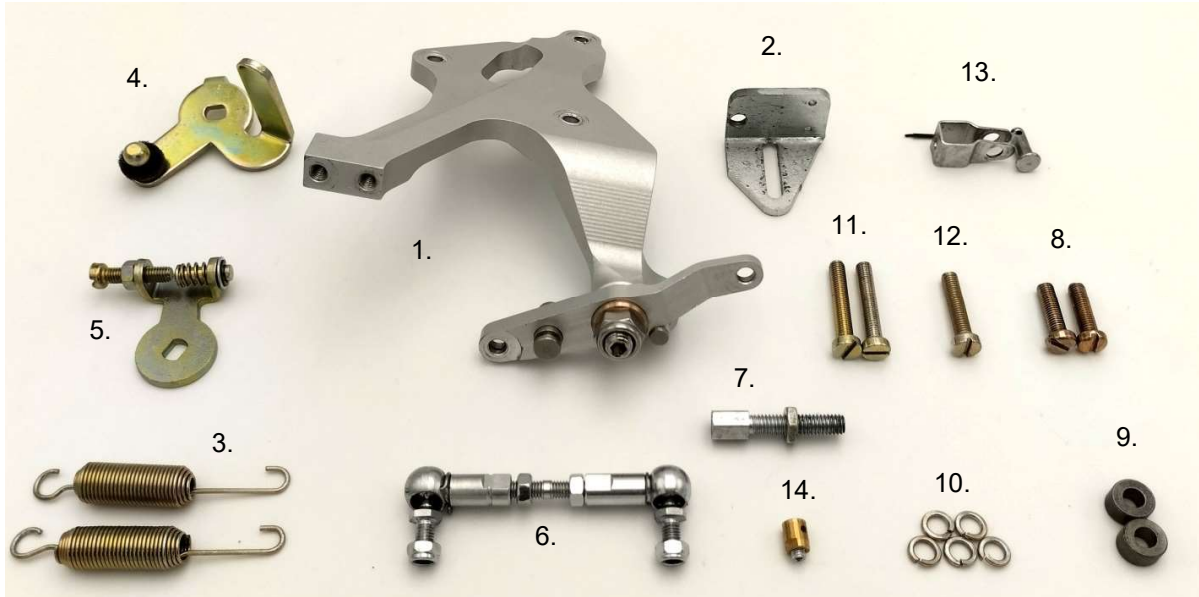

Fig	Part No	Description	Qty
1	9990403500	Top Bracket Assembly	1
2	9990403400	Cable Bracket	1
3	9990115500	Return Spring	2
4	1281	Male Throttle lever	1
5	1282	Female Balance Lever	1
6	9990311400	Linkage Rod Assembly	1
7	9990143000	Cable Outer Adjuster	1
8	9990008200	M5 x 20 Screw	2
9	9990266600	Spacer	2
10	9990002400	Washer Spring	5
11	9990145500	M5 x 30 Screw	2
12	9990076200	M5 x 25 Screw	1
13	9990400800	Cable Fork End Kit	1
14	9990155800	Cable Ferrule	1

## GENERAL NOTES ON INSTALLATION

- It is preferable where possible to fit the throttle levers supplied to the carburettors before installation, and ensure that the throttles open and close freely prior to connecting the throttle linkage.
- Measure the accelerator cable travel on the existing installation, to assist in correctly adjusting the new linkage.
- Lubricate the linkage with light oil during assembly.

## THROTTLE LEVER FITMENT

**N.B.** It may be necessary in certain installations to remove the cast section of manifold between cylinders 2&3 to allow clearance for the new levers (4 & 5).

- Fit the new Throttle Levers (4 & 5) supplied, to the inside facing ends of the two carburettor throttle spindles. If installing on a single carburettor installation, the male connecting lever can be trimmed flush if required.
- IMPORTANT:** When tightening the throttle shaft nut, the throttle lever should be held to avoid twisting the throttle shaft, and care should be taken to ensure the throttle returns to fully closed once the levers have been fitted.

Webcon UK Ltd

Dolphin Road, Sunbury, Middlesex, TW16 7HE. UK  
Tel: +44 (0) 1932 787100 Fax: +44 (0) 1932 782725  
Email: sales@webcon.co.uk Web: www.webcon.co.uk

## LINKAGE ASSEMBLY INSTALLATIONS

- g. Remove the three top cover screws close to the carburettor mounting flange, and discard.
- h. Fit the spring washers (10) to the screws (11) & (12), and attach the Top Bracket Assembly (1) to the top of the carburettor using the M8 x 25 screw (12) closest to the mounting flange and M8 x 30 (11) screws in the two remaining mounting holes. Tighten securely.
- i. Take the adjustable linkage rod (6) and remove the retaining clip from one end and, using a pair of pliers, grip the male end and twist to remove. Discard the male end. At the other end of the rod, remove the Nyloc nut and retain. Screw the thread into the bottom hole of the aluminium lever attached to the top assembly (1) and tighten using an 8mm spanner. Screw the retained Nyloc nut onto the exposed thread, and tighten using an 8mm spanner. Snap the socket end of the rod onto the male ball of the throttle lever and replace the retaining clip. Adjust rod to ensure carburettor can achieve full throttle as well as return to idle, and tighten locknuts.
- j. Attach the Cable Bracket (2) to the Top Bracket Assembly (1) using the two M5 x 20 screws (8), two spring washers (10) and two spacers (9) as per **Fig.1**. but do not tighten.
- k. If installing on late carburettors with white plastic By Pass screw covers, first remove the plastic cover adjacent to the linkage.
- l. Fit the two Return Springs (3) between the cable bracket and the pin on the actuating lever and tighten the two M5 x 20 screws (8) to secure the cable bracket. NB. If extra spring tension is required, undo the two M5 x 20 screws (8), adjust the cable bracket position until the desired spring tension is achieved, and re tighten the screws. **See Fig.1**

## ACCELERATOR CABLE CONNECTION

- m. Select the cable Fork End Kit (14) and fit to the top of the actuating lever, securing with the split pin. **See Fig.2**
- N. Screw the Cable Outer Adjuster (7) into the threaded hole in the Cable Bracket (2) but do not tighten the locknut.
- O. Feed the original cable inner through the Cable Outer Adjuster (7) and then push the original cable outer into the adjuster. Feed the cable inner through the end hole in the Cable Fork end (13). Select the Ferrule (14) and unscrew the grub screw to fully open the side cable hole, using a 2.5mm Allen key. Then feed the cable inner through the hole in the Ferrule (14) and tighten the grub screw fully using a 2.5mm Allen Key.
- P. Place the Ferrule (14) into the Cable Fork, and adjust the Cable Outer Adjuster to allow a small amount of free play in the inner at idle, and to ensure that full throttle can be achieved. **See Fig.3**

**Important: In the full throttle position the throttle pedal should contact either an adjustable pedal stop or the bulkhead just before, or as, the carburettor reaches Wide Open Throttle. This will prevent excessive pedal force from damaging the Carburettor, Throttle Linkage or the Accelerator Inner cable.**



Webcon UK Ltd

Dolphin Road, Sunbury, Middlesex, TW16 7HE. UK  
Tel: +44 (0) 1932 787100 Fax: +44 (0) 1932 782725  
Email: sales@webcon.co.uk Web: www.webcon.co.uk